

ideas<sup>o</sup>  
smart thinking



Cranes, cabins, lifts,  
and materials handling  
solutions

**ideas Pty Ltd**  
2 Rocco Drive, Scoresby VIC 3179  
T: +61 (0)3 9763 4332  
F: +61 (0)3 9763 4321  
[ideas@ideaservices.com.au](mailto:ideas@ideaservices.com.au)  
[www.ideaservices.com.au](http://www.ideaservices.com.au)

## Ideas

ideas\* supply crane services and related equipment to a diverse range of industries such as; aluminium, steel, glass, pulp and paper, mining, grains, bulk materials handling and power generation.



The name of our crane business has changed its trading name once over the years, starting out as AIM Engineering Pty Ltd (AIM) in 1982.

Ian Maisey was the principal force in AIM, providing an experience of over 45 years in the Crane Industry. Prior to AIM, Ian was Engineering Manager for Malcolm Moore Industries, which at the time was the largest Crane Manufacturer in the Southern Hemisphere.



Neil Maisey joined AIM in late 1980's. On Ian's passing in August 1995, Neil became Managing Director and in 1997, Neil purchased AIM Engineering outright. The personnel and equipment from AIM Engineering was transferred to ideas\*, which commenced in 1992, and was founded by Rick Stefanutti and Neil Maisey.

## Services

Cranes are expensive and complex assets. They're expensive to purchase and they're expensive to have sitting idle (causing lost production).

They're complex because they bring with them a responsibility to comply with Australian Standards and Codes of Practice for equipment and safety.

To help you assess the condition of your Crane assets we provide the following inspections:

- Regular condition monitoring programmes
- Spot check (one-off) condition assessments
- Assessment of compliance to relevant standards and codes of practice
- Failure analysis
- Performance optimisation and improvement
- Valuations

We are independent of repair and manufacturing organisations.



## Design

Design and consulting capabilities are spread over 2 sites in Melbourne, covering the major Engineering disciplines (structural, mechanical, electrical, automation, civil, manufacturing, fluid power, materials handling, conveying.)

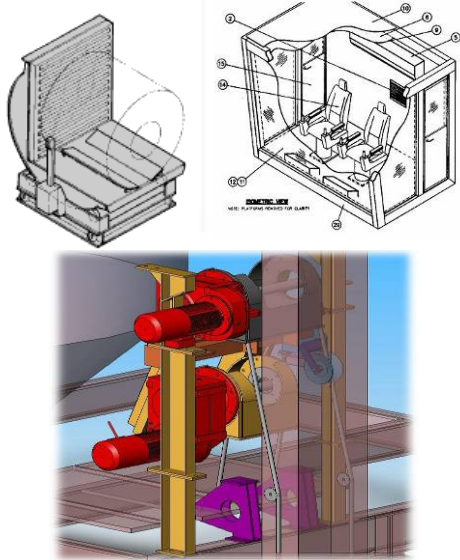

## Cabins

Designed and delivered for ergonomics, operator comfort, vision, and custom design requirements to suit the process and plant. We have several standard designs.



## End of life reviews

Cranes at the end of their design life (typically 25 to 30 years old) are required by Australian Standards to be inspected and assessed for continued use. ideas\* provides preventative maintenance guidance and inspection, end of life reviews, inspections, compliance audits, design reviews, troubleshooting services.



## Management

Purchasing specifications to ensure you purchase a crane that satisfies your needs and complies with relevant standards and codes of practice and the project is executed effectively.

## Up-rating & modification

ideas\* conducts remedial and refurbishment work to existing cranes including repair, capacity up-rating, modernising crane technology, DC to AC conversion and automation.



## Below hook

ideas\* supplies standard and special purpose "below-hook" handling devices (Grabs, C-hooks, Plate handlers, Lifting beams, spreader beams, Rotating handlers, Grabs, tongs.)

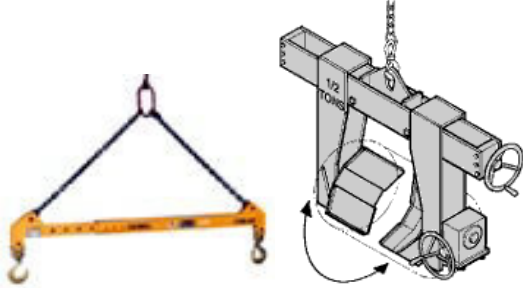

## Turnkey supply

Providing a total turnkey solution forms a large part of our services. We believe that the client should be able to manage his requirements via one point of contact to ensure a clear understanding of project progress.

## Materials handling

ideas\* provides turnkey machine solutions to the manufacturing and processing industries. A large part of ideas\* work is material handling solutions and conducting all the engineering related to the project. Special materials handling equipment is a large part of our service.



## Occupational Health & safety

OH&S is an important part of every business. ideas\* knowledge base and understanding of the standards and legislation allows us to inform and manage our clients risk in this area. We carry out hazard identification and risk assessment and manage the risk mitigation process.

## Special Purpose

ideas\* is expert in understanding your needs and providing a solution which will do the job.



## Our clients

We have a long history in Cranes and boast a diverse range of companies as clients we serve on an ongoing basis including; Alcan (Granville), Alcoa Australia (Point Henry and Portland), Australian Newsprint Mills, BHP Steel (Western Port), Comalco (Bell Bay, Gladstone and Invercargill N.Z.), Hamersley Iron (Tom Price), KAAL Australia (Point Henry), Mt Newman Mining (Mt Whaleback), Smorgon Steel (Laverton) and the Tasmanian Hydro Electric Commission, Simms and many others.