

innovation*
5% great idea,
95% hard work.

discuss your project needs
call Mike Percy (03) 9763 4332

view our recent projects
www.ideaservices.com.au

send us an email
info@ideaservices.com.au

ideas^o
smart thinking

ideas* provides structural, mechanical and electrical engineering services.

Innovative business solutions.

Taking a whole business approach, we apply our technical and business expertise to develop innovative processes, manufacturing and technology solutions.

We have experience across a wide range of industries, with specialisation in the manufacturing, recycling and waste management, materials handling, crane services, and health services sectors.

We believe our key value is realised when we are engaged to help your business identify potential areas for improvement or in developing solutions and project plans for these identified opportunities.

However we also have the resources to carry your project through to implementation.

Deal with experience.

When working with ideas*, you can be assured that you deal directly with our business principals, who are ably supported by our capable team of project engineers and business consultants.

Put simply, you can be confident that your time-critical projects don't get delegated to less-experienced team members, which can often be the case with bigger engineering firms.

a profile detection system continually monitors a conveyor belt system

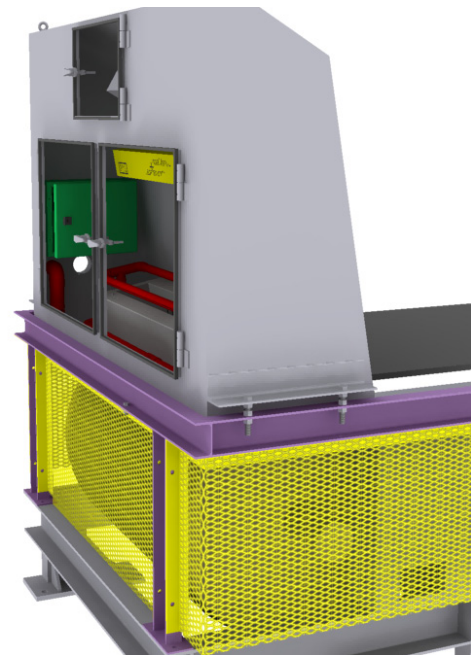

To some innovation is perceived as a risk, we believe doing nothing is a risk.

Taking a smarter approach.

We specialise in assisting companies adapt to today's rapid change by developing new systems and technology that best fits the new business environment.

What worked in the past is no longer working. We believe that there is a better way to provide engineering services, and that taking a smarter approach will lead to better outcomes for our clients.

We also believe that the fundamental way many engineering services firms operate is flawed, having evolved to minimise their own risk, not maximising their clients value.

Adapting to rapid change.

Change. A six letter word, easy to talk about, easy even to identify. Very hard to do.

The real challenge isn't solving a clearly defined problem from the scope of work. It's identifying the opportunity, having the breadth and depth of experience to develop the best solution and dealing with the trade offs and changing requirements of the project as it evolves.

We call this smart thinking.

*crane cabins with
glass bottoms
provide improved
visibility.*

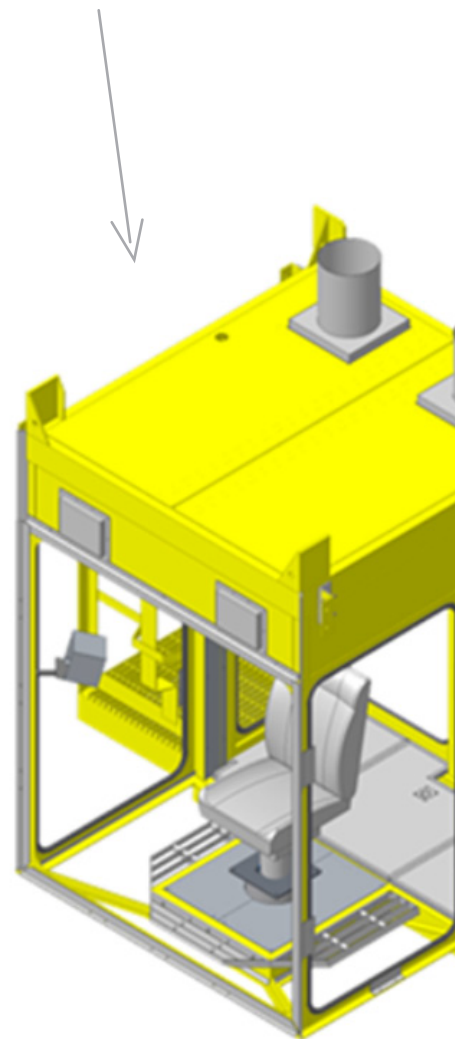

We can manage your project from concept through to implementation.

We are often engaged by clients very early on in the process and have the ability to manage a project from initial concept through to implementation. Key services include:

Opportunity identification

- Process reviews
- Manufacturing analysis
- Materials handling assessments

Project feasibility

- Product development
- System & process development
- Manufacturing plant development
- Industrial equipment design

Project Management

- Project scoping
- Project structuring
- Project needs analysis
- Contractor selection
- Risk analysis & compliance.
- Tendering procedures & protocols
- Project monitoring & auditing
- Project cost control

Engineering design

- Project research & analysis
- Feasibility assessment
- Preliminary design
- Detailed design (see below)
- Production planning & tool design
- Production

Detailed design

- CAD Design & 3D modelling
- Design testing
- Materials and resource assessment
- Maintenance analysis

Process modelling

- Process assessment & analysis
- Process re-engineering

self stacking crate and bottle system for blood plasma collection.

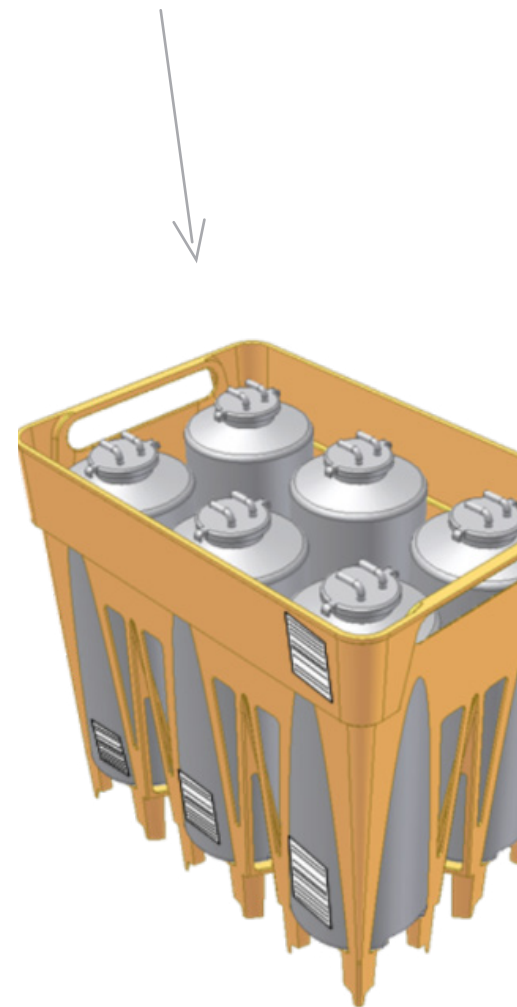

We continue to work with world leading businesses.

The ideas* team has experience across a range of industries including:

Manufacturing

consumer goods, pharmaceutical, industrial products.

Clients Alcoa, Apollo Engineering, ARRB, Bluescope Steel, Bristol Myers-Squibb, Cadbury Schweppes, Carter Holt Harvey, CSL, Dairy Farmers, Dulux Fairfax Printing, Fosters, GlaxoSmithKline, Holden, MOOG, Murray Goulburn, NCI, Orica, Shell, Sims Metal, Wattyl.

Recycling & Waste Management

waste recycling, renewables.

Clients Northstar, Renewed Fuels, Renewed Rubber, Water Savers

Materials Handling

production, storage and transportation.

Clients Alex Fraser Group, Australian Pressure Vessels, Boral Australia, CBM Australia,

Health Services

process and service delivery.

Clients ZLB Plasma Services

The Transverse Profiler takes both laser and ultrasonic measurements of a road surface.

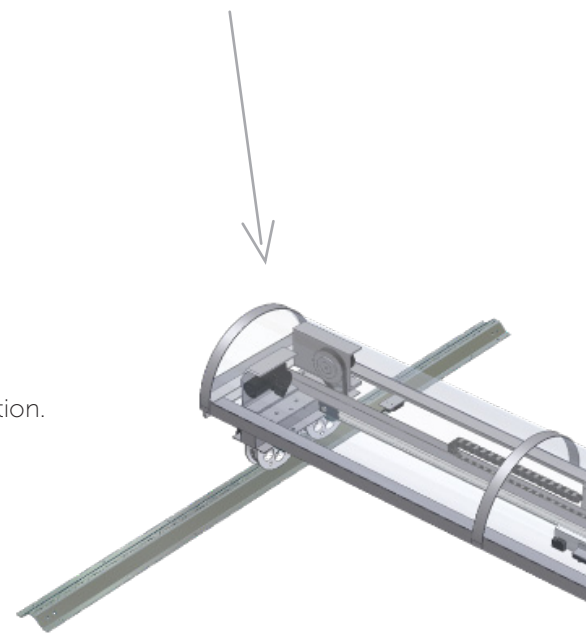

View our recent projects online

visit www.ideaservices.com.au

Deal directly with our business principals.



Mike Percy BA Eng MBA
Managing Director

As Managing Director, Mike has responsibility for overall management and development of the ideas* team. In addition to his general management and strategic experience, Mike's skills in design, project and change management enable him to successfully lead and facilitate major operational change efforts.

He draws upon over 14 years experience with clients including Orica, GlaxoSmithKline, Bristol Myers Squibb, BlueScope Steel and Alcoa.

Most recently Mike has lead a project team for a major upgrade of Dulux's paint manufacturing facilities in Rocklea, Queensland where the objective achieved has significantly reduced the manual processes and implemented a new automatic packaging and product handling process.



Rick Stefanutti BA Eng MBA
Technology Development Director

Rick was a founding partner of ideas* in 1994 and has dedicated his skills to the development of new and emerging technologies and processes for major Australian and International companies for the entire 27 years of his business career.

Much of Rick's experience has been in the manufacturing of products and designing industrial processes. Recently Rick has branched into the renewables sector, with his core competencies being mechanical engineering and process control.

His most recent achievements include leading a major state of the art recycling project for the Alex Fraser Group at Laverton, Victoria.



Geoff Ball BA Eng MBA
Principal Projects Director

Geoff's role as a director and lead consultant for ideas* is enhanced by 15 years experience working within large process businesses (including BlueScope Steel, CSL Ltd).

In a career that includes maintenance engineering, chronic problem solving, systems engineering, project management and organisational change, Geoff has worked in industries as diverse as steel, food, packaging, logistics and bio-pharmaceutical. He understands the demands that drive executives in large organisations enabling his diverse experience to effectively deliver results.

Current projects include a new 'Plasma Centre of the Future' for ZLB, part of the CSL Group, and directing the unique Future Spark project creating innovative leading edge human and solar generated power sources for a large public event.

Contact us to **discuss** your project requirements.

Phone: +61 3 9763 4332

Fax: +61 3 9763 4321

Website www.ideaservices.com.au

Email info@ideaservices.com.au

Office Address

2 Rocco Drive Scoresby
VIC 3179, Australia

To some
innovation is
perceived as a
risk, we believe
doing nothing
is a risk.

discuss your project needs
call Mike Percy (03) 9763 4332

view our recent projects
www.ideaservices.com.au

send us an email
info@ideaservices.com.au

ideas^o
smart thinking